

UNLESS OTHERWISE SPECIFIED:
 DIMENSIONS ARE IN INCHES
 TOLERANCES:
 ANGULAR: $\pm 1/2$ DEG
 DECIMAL: .X ± 0.063
 .XX ± 0.031
 .XXX ± 0.015
 HOLES: UNDER 0.500 ± 0.005
 OVER 0.501 ± 0.010

DO NOT SCALE DRAWING

MATERIAL

FINISH

	NAME	DATE	PRODUCT:
DRAWN	JB	5/14/15	-
CHECKED			
ENG APPR.			
MFG APPR.			
DERIVED FROM			
COMMENTS:	-		



TITLE:

VL1 Assembly
line drawing

SIZE
A

PART. NO.

REV
A

SCALE: 1:2

WEIGHT:

SHEET 1 OF 1

A

B

C

D

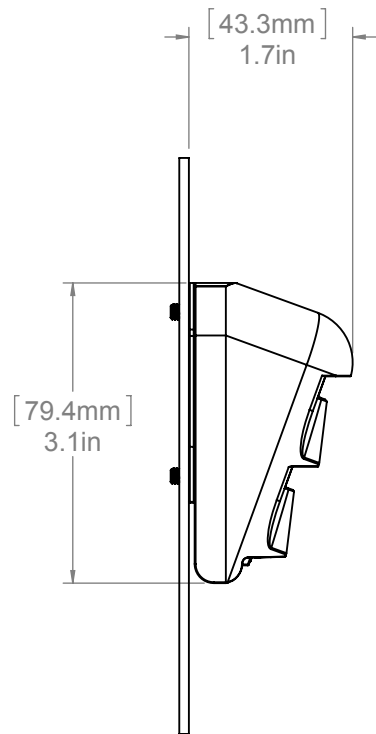

[34mm]
1.3in

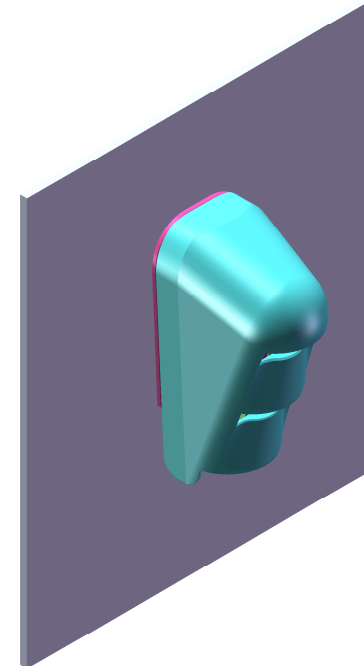
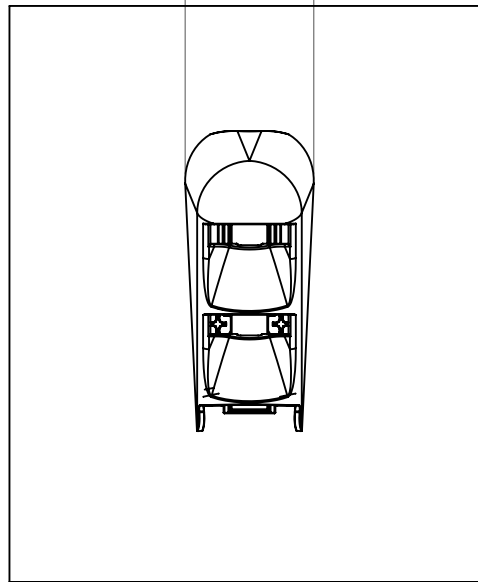

UNLESS OTHERWISE SPECIFIED:
DIMENSIONS ARE IN INCHES
TOLERANCES:
ANGULAR: $\pm 1/2$ DEG
DECIMAL: .X ± 0.030
.XX ± 0.015
.XXX ± 0.005
HOLES: UNDER 0.500 $\begin{matrix} 0.005 \\ \pm \\ 0.010 \end{matrix}$
OVER 0.501

DO NOT SCALE DRAWING

MATERIAL
As Noted

FINISH
As Noted

NAME DATE

JBB 5/14/15

PRODUCT:

-

DRAWN

CHECKED

ENG APPR.

MFG APPR.

DERIVED FROM

COMMENTS:

-

TITLE:

VL2 line drawing

SIZE
A

PART. NO.

REV
A

SCALE: 1:2

WEIGHT:

SHEET 1 OF 1

tempo[®]

8 7 6 5 4 3 2 1

D
C
B
A

D
C
B
A

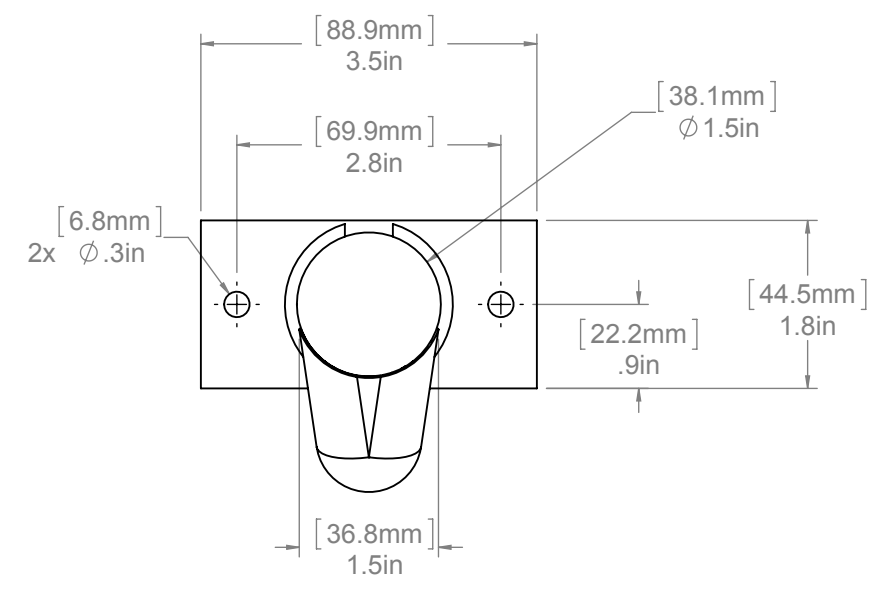
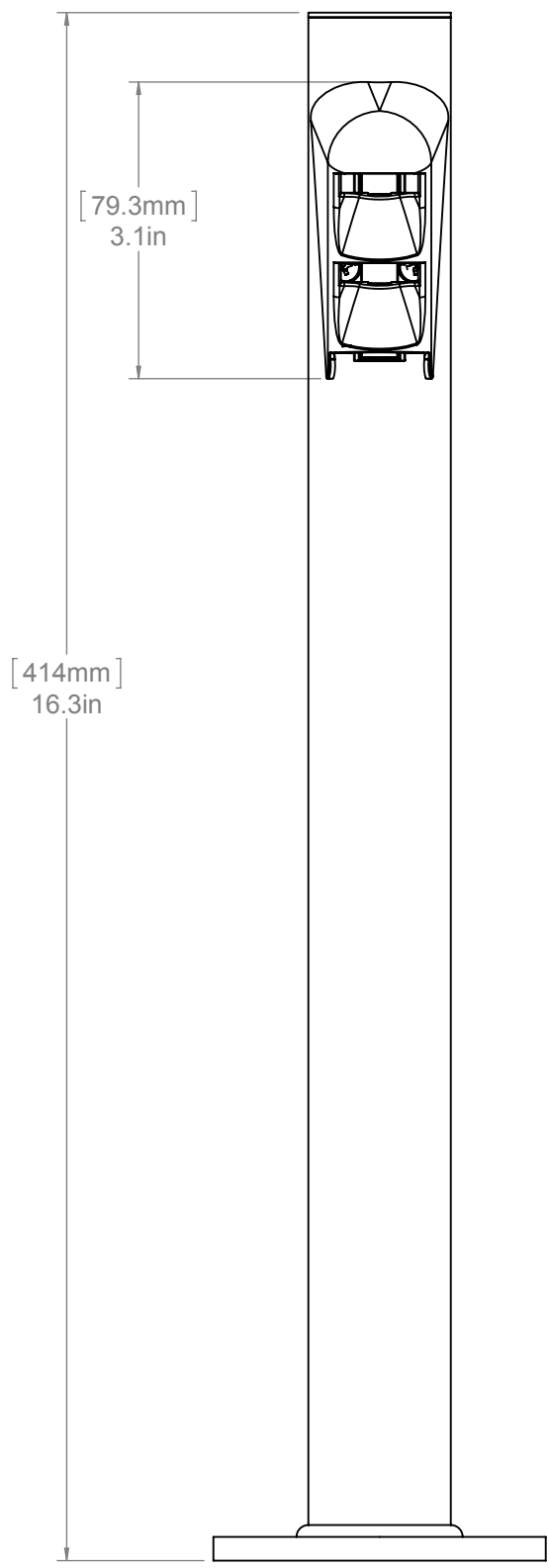
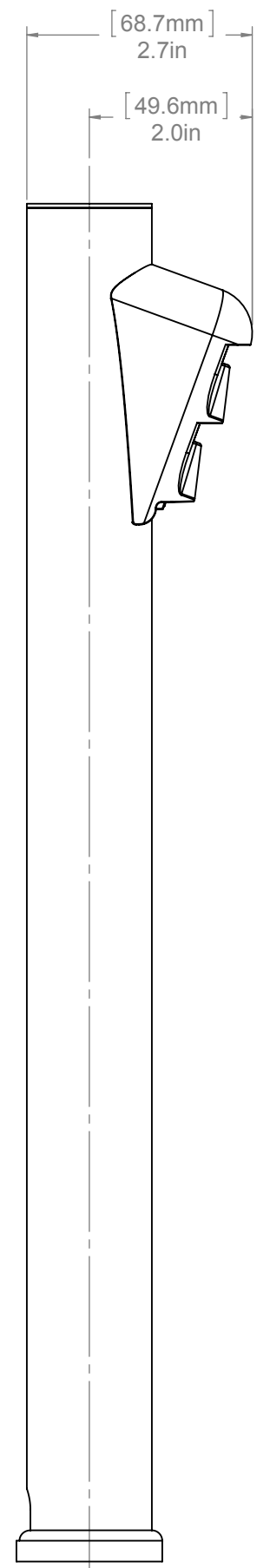

The information contained in this document is the sole property of Tempo Industries. Reproduction in part or as a whole without the written permission of Tempo Industries Inc., is prohibited.

UNLESS OTHERWISE SPECIFIED: DIMENSIONS ARE IN INCHES TOLERANCES: ANGULAR: ±1/2DEG DECIMAL: .X ±0.030 .XX ±0.015 .XXX ±0.005 HOLES: UNDER 0.500 0.005 ± OVER 0.501 0.010 ± INTERPRET GEOMETRIC TOLERANCING PER: MATERIAL As Noted FINISH As Noted DO NOT SCALE DRAWING	NAME	DATE	 TITLE: VPL1 Line Drawing	
	DRAWN	JBB		5/14/15
	CHECKED			
	ENG APPR.			
	MFG APPR.			
	Q.A.			
	COMMENTS:			
	SIZE	PART. NO.	REV	
	B		-	
	SCALE: 1:2	WEIGHT:	SHEET 1 OF 1	

8 7 6 5 4 3 2 1